

CERAMIC HOBS

WHC642BA, WHC742BA, WHC644SA,
WHC942BA, WHC322BA

CONGRATULATIONS

Dear customer,

Congratulations and thank you for choosing our cooktop.

We are sure you will find it a pleasure to use. Before you use the cooktop, we recommend that you read through the relevant sections of this manual, which provides a description of your appliance and its functions.

To avoid the risks that are always present when you use an appliance, it is important that the appliance is installed correctly and that you read the safety instructions carefully to avoid misuse and hazards.

We recommend that you keep this instruction booklet for future reference and pass it on to any future owners.

After unpacking the appliance, please check it is not damaged. If in doubt, do not use the appliance but contact your local customer care centre.

This appliance complies with requirements of Australian Standards AS/NZS 60335.2.6.

Conditions of use

This appliance is intended to be used in household and similar applications such as:

- Staff kitchen areas in shops, offices and other working environments
- Farm houses
- By clients in hotels, motels and other residential type environments
- Bed and breakfast type environments
- Catering and similar non-retail applications

Please ensure you read the instruction manual fully before you call for service, or a full service fee could be applicable.

Record model and serial number here:

Model number:.....

Serial number:.....

PNC:.....

CONTENTS

Important safety instructions.....	3
Product description	4
WHC642BA	
WHC742BA	
WHC644SA,	
WHC942BA	5
WHC322BA	
Using your cooktop.....	6
Cleaning your cooktop	7
Troubleshooting.....	8
Technical data.....	8
Installing your cooktop.....	9
Warranty.....	15

Please read the user manual carefully and store in a handy place for later reference.

The symbols you will see in this booklet have these meanings:



WARNING

This symbol indicates information concerning your personal safety.



CAUTION

This symbol indicates information on how to avoid damaging the appliance.



IMPORTANT

This symbol indicates tips and information about use of the appliance.



ENVIRONMENT

This symbol indicates tips and information about economical and ecological use of the appliance.

IMPORTANT SAFETY INSTRUCTIONS

Please read the user manual carefully and store in a handy place for later reference.



IMPORTANT

Important – check for any damages or marks

If you find the appliance is damaged or marked, you must report it within 7 days if you wish to claim for damage/marks under the manufacturer's warranty. This does not affect your statutory rights.



ENVIRONMENT

Information on disposal for users

- Most of the packing materials are recyclable. Please dispose of those materials through your local recycling depot or by placing them in appropriate collection containers.
- If you wish to discard this product, please contact your local authorities and ask for the correct method of disposal.



WARNING

These warnings have been provided in the interest of safety. You **MUST** read them carefully before installing or using the appliance.

- An authorised person must install this appliance and carry out servicing. (Certificate of Compliance to be retained)
- This appliance must be earthed.
- In order to avoid any potential hazard, the enclosed installation instructions must be followed.
- Do not modify this appliance.
- This appliance must not be used as a space heater.
- Ensure the appliance is switched off before cleaning. This can be done by switching off the appliance via the powerpoint or isolating switch (if available), or the switchboard.
- Do not use steam cleaners, as this may cause moisture build up.
- Always keep the appliance clean.
- Do not use the appliance as a storage area or work surface.
- Do not place or store flammable liquids, highly inflammable materials or fusible objects (e.g. plastic film, plastic, aluminium) on or near the appliance.
- Do not leave the appliance on unattended.
- This appliance is not intended for use by persons (including children) with reduced physical, sensory or mental capabilities, or lack of experience and knowledge, unless they have been given supervision or instruction concerning use of the appliance by a person responsible for their safety.
- Children should be supervised to ensure that they do not play with the appliance.
- Accessible parts will become hot when in use. To avoid burns and scalds children should be kept away.
- During use, this appliance becomes hot. Care should be taken to avoid touching hot surfaces.

- Ensure that all electrical cables are kept well clear of the appliance during use.
- Overheated fats and oils can ignite very quickly. When cooking with fat or oil do not leave the appliance unattended.
- Switch the cooking zones off after each use.
- To maintain safe operation, it is recommended that the product be inspected every 5 years by an authorised service person.
- In the event of faults with the appliance or damage to the glass ceramic (cracks, scratches or splits), the appliance must be switched off and disconnected from the electrical supply to prevent the possibility of an electric shock.



CAUTION

Read the following carefully to avoid damage to the appliance.

- Before using the appliance, ensure that all packing materials are removed from the appliance. Remove stickers and film from the glass ceramic.
- Wipe away protective oil using a mild detergent and a clean damp cloth.
- Do not use harsh abrasive cleaners, powder cleaners, steel wool or wax polishes on this appliance.
- With the exception of razor blade scrapers designed for ceramic glass cleaning, (provided with some models or available to purchase through our spare parts) do not use sharp metal implements or utensils on any surface, as these may leave permanent scratches or marks.
- Always clean the appliance immediately after any food spills.
- This appliance may only be used after being built into a suitable benchtop according to the guidelines provided.
- The glass ceramic can be damaged by objects falling onto it. Care should be taken when using heavy cookware to avoid damaging the glass top and edges.
- Cookware made of cast iron, cast aluminium or with damaged bottoms can scratch the glass ceramic if dragged across the surface. Cookware should be lifted in and out of position rather than dragged or pushed.
- Food that melts and boils over can burn onto the glass ceramic surface and should be removed straight away.
- To avoid damaging the glass ceramic and cookware do not allow saucepans or frying pans to boil dry.
- Do not use the cooking zones with empty cookware or without cookware.

NOTE: You must read these warnings carefully before installing or using the appliance. If you need assistance, contact your Customer Care Centre. The manufacturer will not accept liability, should these instructions or any other safety instructions incorporated in this book be ignored.

PRODUCT DESCRIPTION

WHC642BA
WHC742BA

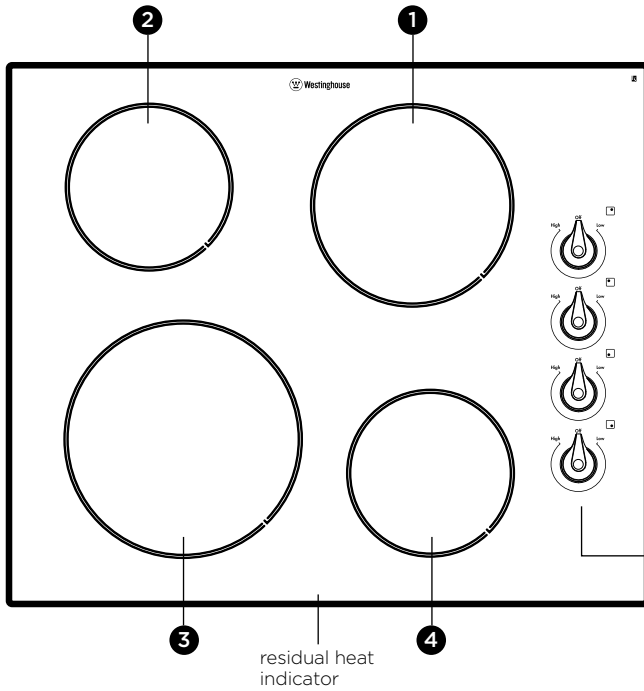

- ❶ Single 180mm diameter cooking zone 1800W
- ❷ Single 145mm diameter cooking zone 1200W
- ❸ Single 210mm diameter cooking zone 2300W
- ❹ Single 145mm diameter cooking zone 1200W

hob cooking zone control knobs

WHC644SA

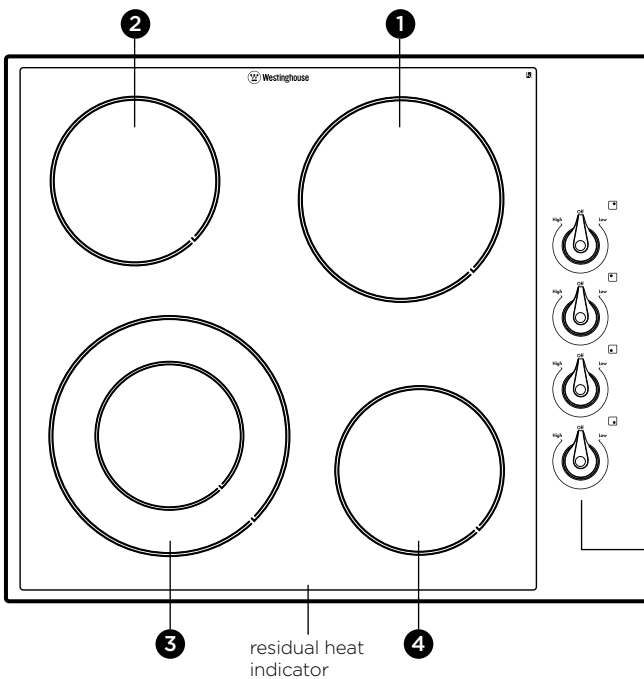

- ❶ Single 180mm diameter cooking zone 1800W
- ❷ Single 145mm diameter cooking zone 1200W
- ❸ Dual 210 diameter cooking zone 750/2200W
- ❹ Single 145mm diameter cooking zone 1200W

hob cooking zone control knobs

WHC942BA

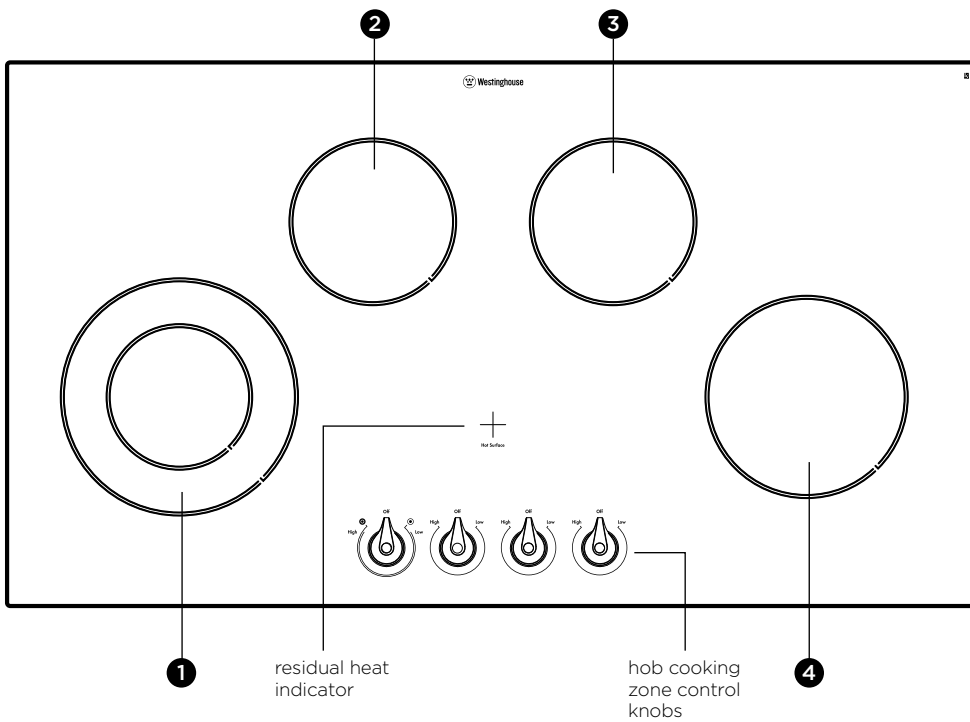

- ❶ Double 210mm diameter cooking zone 750/2200
- ❷ Single 145mm diameter cooking zone 1200W
- ❸ Single 145mm diameter cooking zone 1200W
- ❹ Single 180mm diameter cooking zone 1800W

WHC322BA

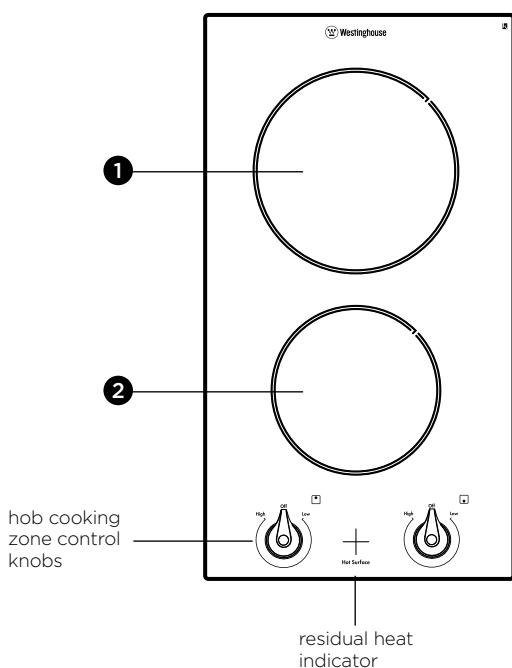

- ❶ Single 200mm diameter cooking zone 1800W
- ❷ Single 165mm diameter cooking zone 1200W

OPERATING YOUR APPLIANCE



IMPORTANT

When a cooking zone is switched on it may hum briefly. This is a characteristic of all ceramic glass cooking zones and does not impair either the function or the life of the appliance.

Controlling the temperature - single zone

To increase the heat, turn the control knob clockwise.

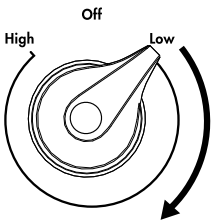

To decrease the heat, turn the control knob anti-clockwise.

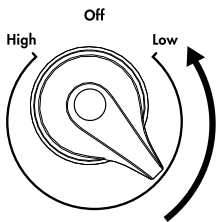

To switch off, turn the control knob to the off position.

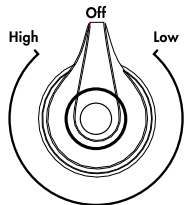

When boiling water or searing food select a high setting. As soon as steam forms or the fat or oil is hot, set a lower heat setting. To end the cooking process, turn the knob to the 'Off' position.



IMPORTANT

The Ring Control Knobs for single cooking zones can be turned either right or left.

Controlling the temperature - dual zone

By switching the outside ring on and off, the effective heating surface can be matched to the size of the cookware.



IMPORTANT

The inside ring must be switched on before switching on the outside ring.

To turn the outside ring on, turn the control knob clockwise past a slight resistance, as far as it will go. The inside ring must be switched on before turning on the outside ring.

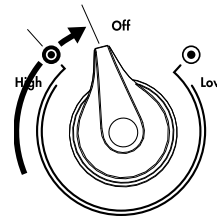

Turn the control knob anti-clockwise to reach the desired setting.

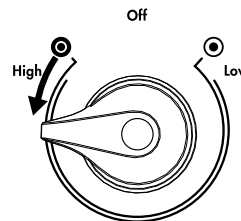

To switch off, turn the control knob to the off position.

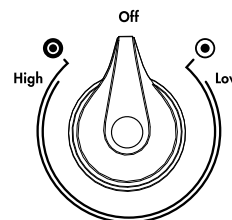

Cookware

For optimal results use good quality cookware with a heavy flat base. Cookware made of enamelled or with aluminium or copper bottoms can leave discolourations on the glass ceramic surface which are difficult or impossible to remove.



ENVIRONMENT

- Always place the cookware on the cooking zone before it is switched on.
- If possible, always place the lids on the pans.
- Switch the cooking zones off before the end of the cooking time to take advantage of the residual heat.
- Ensure the bottom of the pan is the same size as the cooking zone you are using.

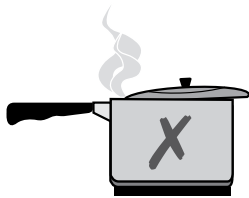

Allowing heat to escape during cooking increases cooking time and energy consumption

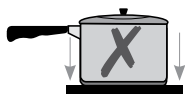
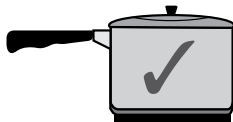

Using the wrong size pot for the cooking zone allows heat to escape



CARE AND CLEANING

General cleaning



WARNING

Ensure that the appliance is turned off and all residual heat has dissipated before attempting to clean the cooktop.



CAUTION

Sharp objects and abrasive cleaning materials will damage the appliance. To prevent scratches to the surface only non-scratch scourers should be used. Damage caused by abrasive cleaning materials is not covered by the Warranty.



CAUTION

Residue from cleaning agents may damage or stain the appliance. Damage caused by residual cleaning agents is not covered by the Warranty.

Wipe the appliance with a mild detergent and a soft, damp cloth. Remove all residue after cleaning and dry with a soft cloth.

Removing deposits

1. Place a scraper* on the glass ceramic surface at an angle.
2. Remove residue by sliding the blade over the surface.
3. Wipe the appliance clean with a mild detergent and a damp cloth.
4. Dry the appliance using a clean, dry cloth.

* Provided with selected models or available for purchase as an accessory.



IMPORTANT

Sugar, food containing sugar, plastics and tin foil should be removed immediately with a scraper.

Limescale, water rings, fat splashes and metallic discolouration should be removed with a glass ceramic or stainless steel cleaner when the appliance has cooled down.

Scratches or dark stains on the glass ceramic that cannot be removed do not affect the functioning of the appliance.

TROUBLESHOOTING

PROBLEM	CAUSES	REMEDY
The cooking zones are not functioning.	<ul style="list-style-type: none"> The desired heat setting is not set. The fuse in the house's electrical wiring (fuse box) has been tripped. 	<ul style="list-style-type: none"> Set the heat setting. Check the fuse. If the fuse continues to trip, please call an authorised electrician.
The residual heat indicator is not displaying anything.	<ul style="list-style-type: none"> The cooking zone was only on for a short period of time and is therefore not hot. 	<ul style="list-style-type: none"> If the cooking zone is hot, call the Customer Service Department.
Red rings, limescale or water rings, shiny metallic or other discolouration, scratches/shadows, bubbles or other miscellaneous stains on ceramic glass cooktop surfaces.	<ul style="list-style-type: none"> Cooktop surface has not been cleaned correctly. Cleaning/maintenance of the cooktop surface is not covered under warranty. If a service call is placed to clean the cooktop you will be charged for the visit. 	<ul style="list-style-type: none"> Use a ceramic glass cleaner such as Cerapol.
Pitting of ceramic glass surface.	<ul style="list-style-type: none"> Spillovers of liquid with high sugar content. 	<ul style="list-style-type: none"> These types of spills must be removed immediately with a special scraper for the glass. If not, permanent damage to the cooktop glass can occur which is not covered under warranty.
The residual heat indicator is not displaying anything.	<ul style="list-style-type: none"> The cooking zone was only on for a short time and is therefore not hot. 	<ul style="list-style-type: none"> If the cooking zone is supposed to be hot, call the Customer Service Department.
Outer ring on double ring element won't turn on.	<ul style="list-style-type: none"> Control knob has not been turned far enough. 	<ul style="list-style-type: none"> Turn control knob clockwise, past a slight resistance. Refer instructions on page 6.

If you are unable to remedy the problem by following the above suggestions, please contact your dealer or the Customer Care Department.



WARNING

Repairs to the appliance are only to be carried out by qualified service engineers due to the risk of electric shock.



CAUTION

If the appliance has been wrongly operated or installed, service calls may not be covered under the Warranty.

TECHNICAL DATA

MODEL	WHC642BA		WHC742BA		WHC644SA		WHC942BA		WHC322BA	
PNC	949 163 180		949 163 179		949 163 181		949 163 178		949 163 182	
Product dimensions (w x d mm)	590x520		700x520		606x505		900x520		320x520	
Cut out dimensions (w x d mm)	560x490		560x490		560x490		880x490		300x490	
Power (kW)	6.5		6.5		6.4		6.4		3.0	
Service cord	hardwired		hardwired		hardwired		hardwired		hardwired	
Elements	No. of zones	Watts	No. of zones	Watts	No. of zones	Watts	No. of zones	Watts	No. of zones	Watts
Front left	1	2300	1	2300	2	750/2200	2	750/2200	1	1200
Rear left	1	1200	1	1200	1	1200	1	1200	1	1800
Front right	1	1200	1	1200	1	1200	1	1800		
Rear right	1	1800	1	1800	1	1800	1	1200		
Total	4	6.5	4	6.5	5	6.4	5	6.4	2	3.0

INSTALLING YOUR APPLIANCE



WARNING

To avoid any potential hazard, you must follow our instructions when you install your appliance. Failure to install the appliance correctly could invalidate any warranty or liability claims and lead to prosecution.

- This appliance must be installed by an authorised person according to all codes and regulations as stated in the local municipal building code and other relevant statutory regulations.
- Wiring connections must be in accordance with AS/NZS 3000 Wiring Rules and any particular conditions of the local authority.
- Wiring should be protected against mechanical failure. Refer to AS/NZS3000 clauses 3.3.2.6, 3.9, 3.10
- A means of disconnection with a contact separation of at least 3mm must be supplied in the fixed wiring.
- This appliance must be installed by an authorised person according to all codes and regulations as stated in the local municipal building code and other relevant statutory regulations.
- The minimum distances to other appliances and units are to be observed.
- Turn off the power at the mains before installing this appliance.
- Supply cords must have a temperature rating not less than 105°C.
- The surface temperature of the appliance exceeds 95°C. Underbench access must be restricted to prevent a hazard.
- The clamping joints must be installed by a qualified electrician.
- The electrical schematic must be observed.

Electrical connection

Before connecting, check that the nominal voltage of the appliance stated on the rating plate, corresponds to the available supply voltage. The rating plate is located on the lower casing of the hob.

The hob is to be connected to the mains using a device that allows the appliance to be disconnected from the mains at all poles with a contact opening width of at least 3mm. eg. automatic line protecting cut-out, earth leakage trips or fuse. A cable with a minimum temperature rating of V90HT or higher must be used as the mains connecting cable.

The connection must be carried out as shown in the diagram. The connecting links should be fitted according to the appropriate connection diagram. The earth lead is connected to terminal.



The earth leads must be longer than the leads carrying the electrical current.

The cable conditions must be in accordance with regulations and the terminal screws tightened securely.

The connecting cable is to be secured with the mains cable cleat and the covering closed by pressing firmly (lock into place).

Before switching on for the first time, any protective foil or stickers must be removed from the glass ceramic surface.



IMPORTANT

Once connected to the mains supply, check that all the cooking zones are ready for use by briefly switching each on in turn at the maximum setting.

INSTALLING YOUR APPLIANCE (CONTINUED)

Applying the seal

- Clean the worktop around the cut-out area.
- Stick the single-sided adhesive sealing tape provided around the outside edge of the underside of the hob, ensuring that it is not stretched. The 2 ends of the tape should join in the middle of one side. Allow the tape to overlap by 2-3mm, trim, and press the 2 ends together.

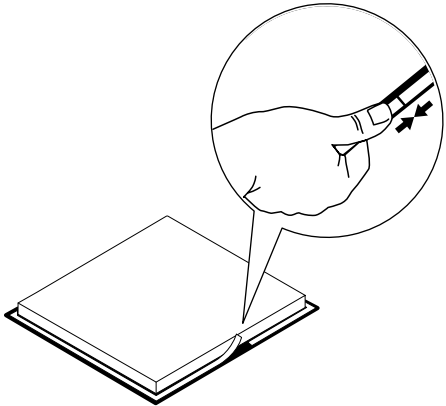

Assemble spring clips as shown, to support unit in benchtop.

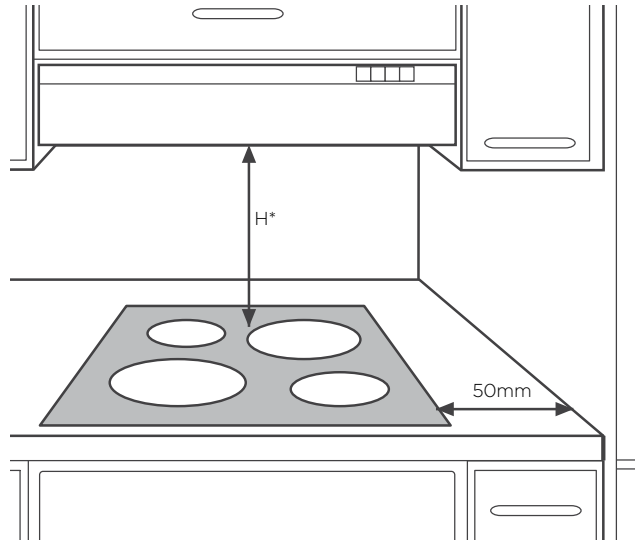
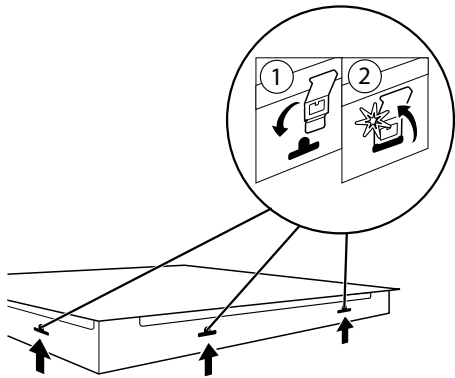

The cooktop must be installed at least 50mm from any combustible surface.

H* - refer to rangehood manufacturers installation instructions for minimum height from cooktop.

WHC642BA

WHC644SA

WHC742BA

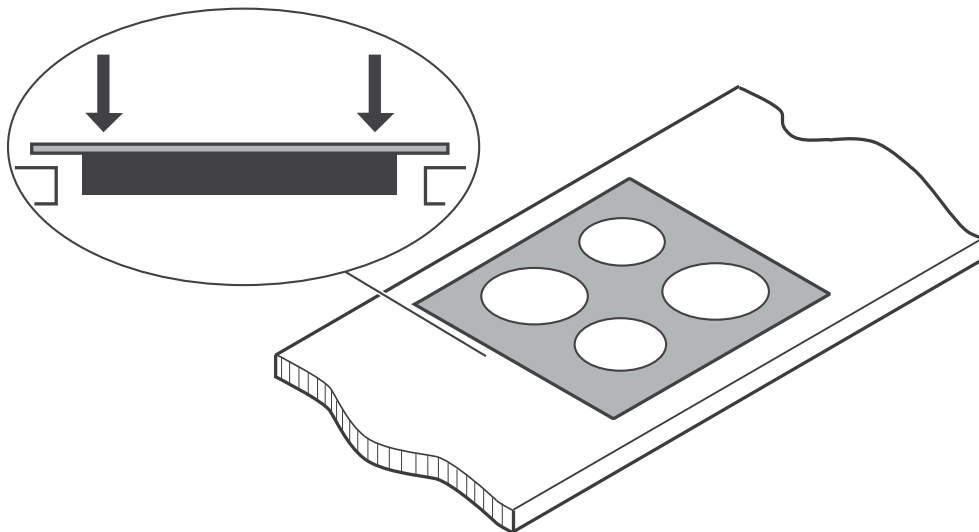
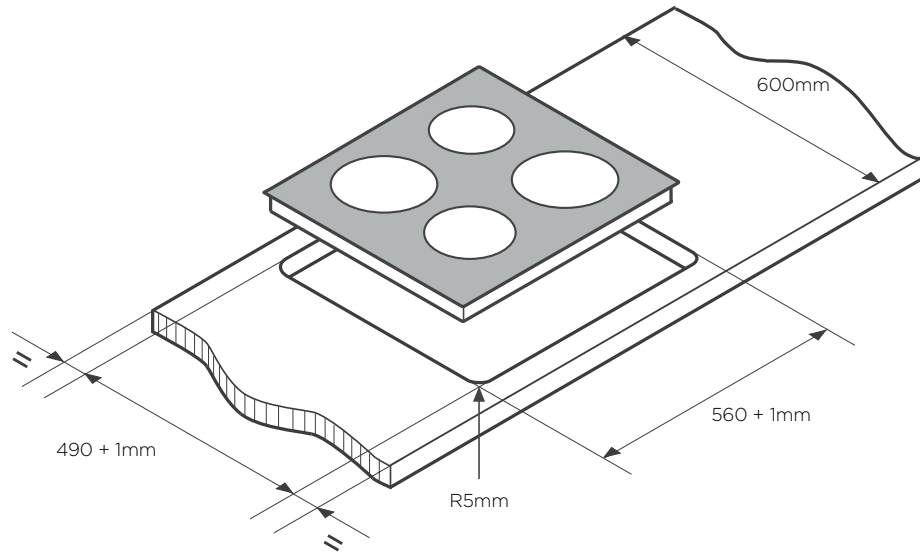

INSTALLING YOUR APPLIANCE (CONTINUED)

WHC942BA

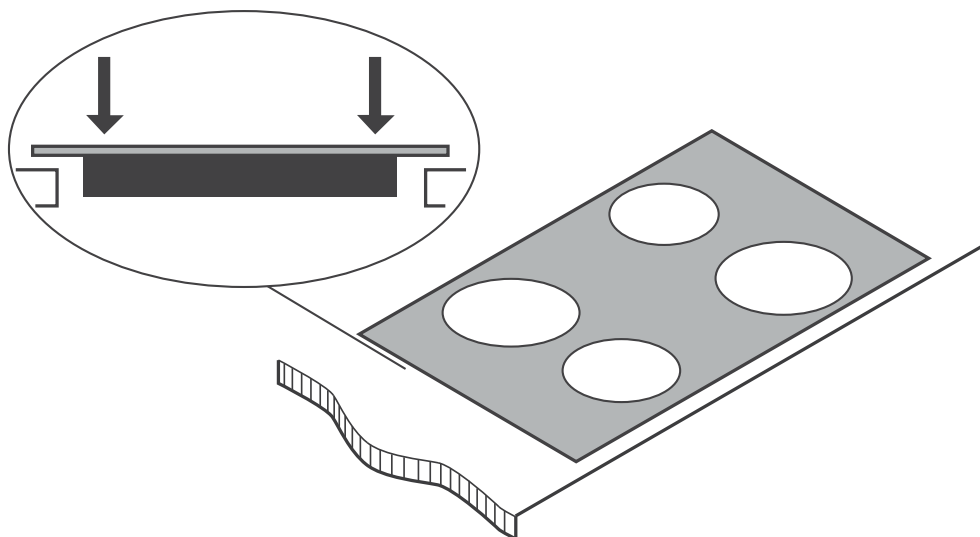
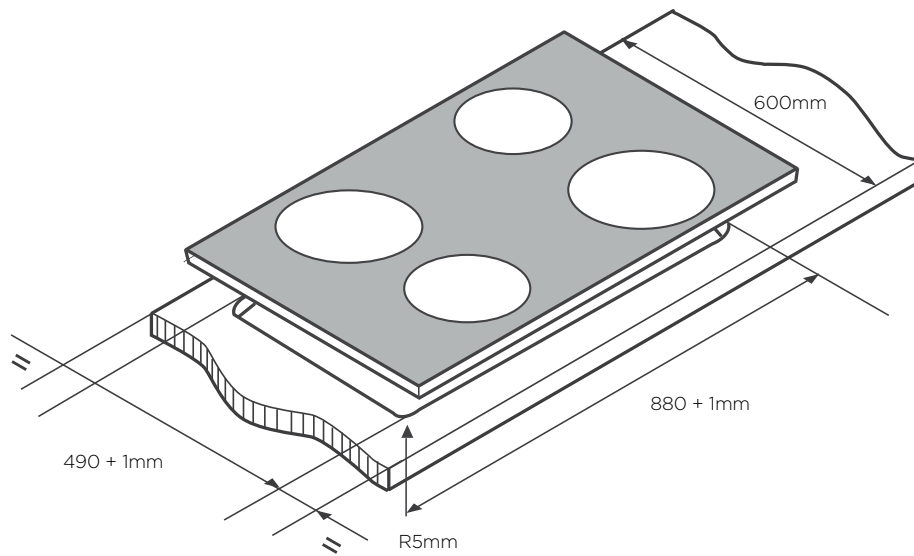

WHC322BA

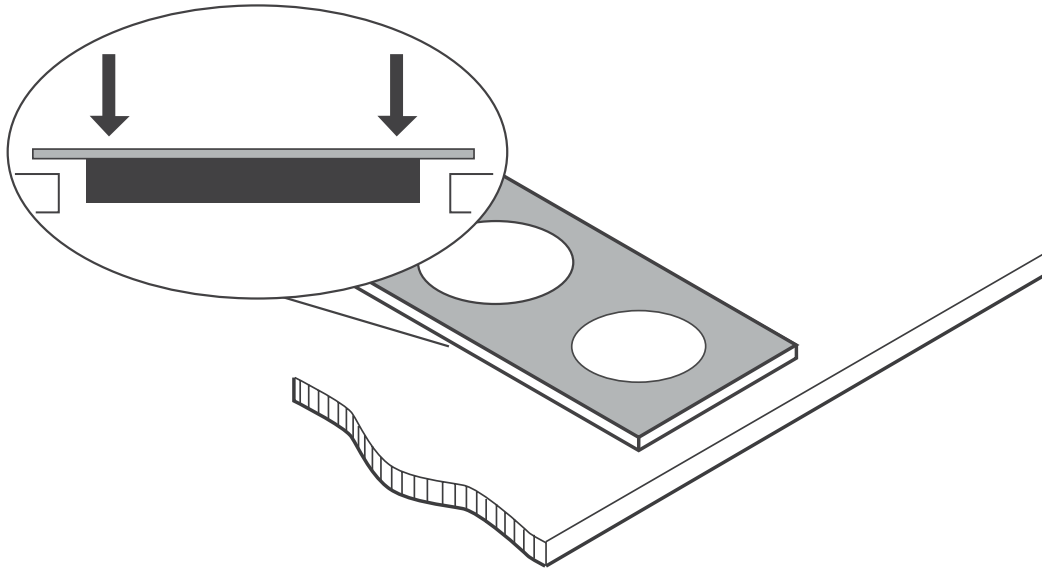
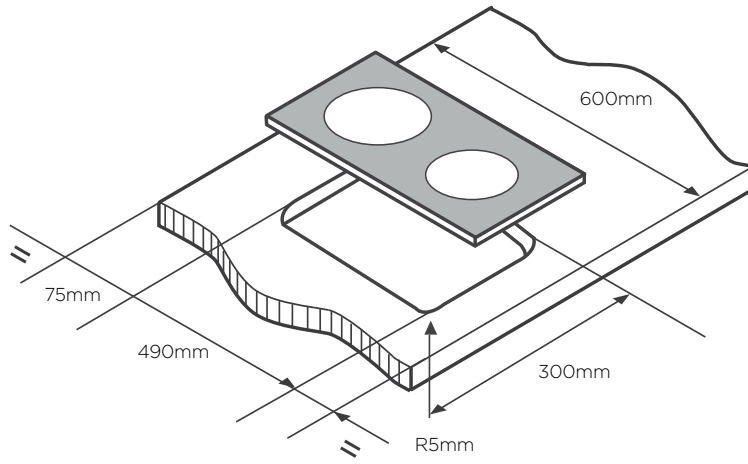

INSTALLING YOUR APPLIANCE (CONTINUED)

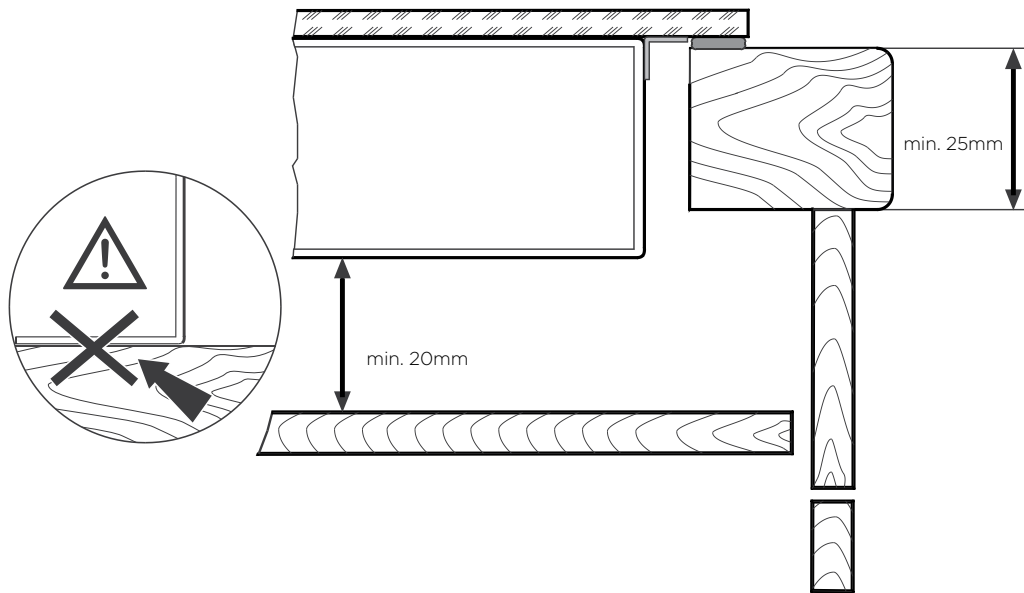

Installation above cupboards or drawers

Under hob access must be restricted by the addition of a board mounted at least 20mm from the underside of the hob.

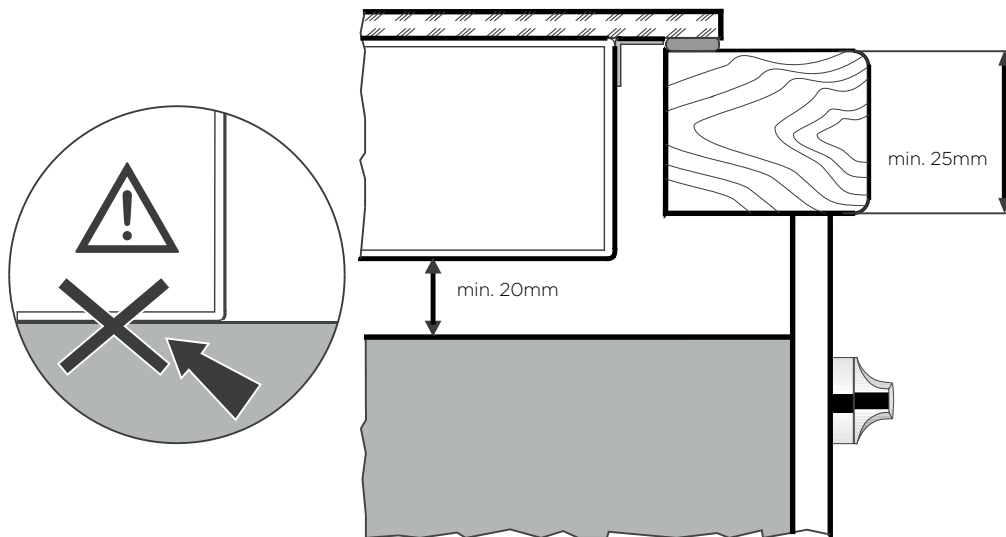

Installation above an appliance

The hob must be mounted at least 20mm from the top of an appliance.



FOR SALES IN AUSTRALIA AND NEW ZEALAND
 APPLIANCE: BUILT-IN OVEN, COOKTOP
 AND FREESTANDING COOKERS

This document sets out the terms and conditions of the product warranties for Electrolux Appliances. It is an important document. Please keep it with your proof of purchase documents in a safe place for future reference should you require service for your Appliance.

1. In this warranty:
 - (a) 'acceptable quality' as referred to in clause 10 of this warranty has the same meaning referred to in the ACL;
 - (b) 'ACL' means Schedule 2 to the Competition and Consumer Act 2010;
 - (c) 'Appliance' means any Electrolux product purchased by you and accompanied by this document;
 - (d) 'ASC' means Electrolux authorised service centres;
 - (e) 'Electrolux' means Electrolux Home Products Pty Ltd of 163 O'Riordan Street, Mascot NSW 2020, ABN 51 004 762 341 in respect of Appliances purchased in Australia and Electrolux (NZ) Limited (collectively 'Electrolux') of 3-5 Niall Burgess Road, Mount Wellington, in respect of Appliances purchased in New Zealand;
 - (f) 'major failure' as referred to in clause 10 of this warranty has the same meaning referred to in the ACL and includes a situation when an Appliance cannot be repaired or it is uneconomic for Electrolux, at its discretion, to repair an Appliance during the Warranty Period;
 - (g) 'Warranty Period' means the Appliance is warranted against manufacturing defects in Australia for 24 months and in New Zealand for 24 months, following the date of original purchase of the Appliance;
 - (h) 'you' means the purchaser of the Appliance not having purchased the Appliance for re-sale, and 'your' has a corresponding meaning.
2. This warranty only applies to Appliances purchased and used in Australia or New Zealand and used in normal domestic applications and is in addition to (and does not exclude, restrict, or modify in any way) any non-excludable statutory warranties in Australia or New Zealand.
3. During the Warranty Period Electrolux or its ASC will, at no extra charge if your Appliance is readily accessible for service, without special equipment and subject to these terms and conditions, repair or replace any parts which it considers to be defective. Electrolux or its ASC may use remanufactured parts to repair your Appliance. You agree that any replaced Appliances or parts become the property of Electrolux. This warranty does not apply to light globes, batteries, filters or similar perishable parts.
4. Parts and Appliances not supplied by Electrolux are not covered by this warranty.
5. To the extent permitted by law, you will bear the cost of transportation, travel and delivery of the Appliance to and from Electrolux or its ASC. If you reside outside of the service area, you will bear the cost of:
 - (a) travel of an authorised representative;
 - (b) transportation and delivery of the Appliance to and from Electrolux or its ASC.

In all instances, unless the Appliance is transported by Electrolux or an Electrolux authorised representative, the Appliance is transported at the owner's cost and risk while in transit to and from Electrolux or its ASC.
6. Proof of purchase is required before you can make a claim under this warranty.
7. You may not make a claim under this warranty unless the defect claimed is due to faulty or defective parts or workmanship. Electrolux is not liable in the following situations (which are not exhaustive):
 - (a) the Appliance is damaged by:
 - (i) accident
 - (ii) misuse or abuse, including failure to properly maintain or service
 - (iii) normal wear and tear
 - (iv) power surges, electrical storm damage or incorrect power supply
 - (v) incomplete or improper installation
 - (vi) incorrect, improper or inappropriate operation
 - (vii) insect or vermin infestation
 - (viii) failure to comply with any additional instructions supplied with the Appliance;
 - (b) the Appliance is modified without authority from Electrolux in writing;
 - (c) the Appliance's serial number or warranty seal has been removed or defaced;
 - (d) the Appliance was serviced or repaired by anyone other than Electrolux, an authorised repairer or ASC.
8. This warranty, the contract to which it relates and the relationship between you and Electrolux are governed by the law applicable where the Appliance was purchased. Where the Appliance was purchased in New Zealand for commercial purposes the Consumer Guarantee Act does not apply.
9. To the extent permitted by law and subject to your non-excludable statutory rights and warranties, Electrolux excludes all warranties and liabilities (other than as contained in this document) including liability for any loss or damage whether direct or indirect arising from your purchase, use or non use of the Appliance.
10. For Appliances and services provided by Electrolux in Australia, the Appliances come with a guarantee by Electrolux that cannot be excluded under the ACL. You are entitled to a replacement or refund for a major failure and for compensation for any other reasonably foreseeable loss or damage. You are also entitled to have the Appliance repaired or replaced if the Appliance fails to be of acceptable quality and the failure does not amount to a major failure. The benefits to you given by this warranty are in addition to your other rights and remedies under a law in relation to the Appliances or services to which the warranty relates.
11. At all times during the Warranty Period, Electrolux shall, at its discretion, determine whether repair, replacement or refund will apply if an Appliance has a valid warranty claim applicable to it.
12. For Appliances and services provided by Electrolux in New Zealand, the Appliances come with a guarantee by Electrolux pursuant to the provisions of the Consumer Guarantees Act, the Sale of Goods Act and the Fair Trading Act.
13. To enquire about claiming under this warranty, please follow these steps:
 - (a) carefully check the operating instructions, user manual and the terms of this warranty;
 - (b) have the model and serial number of the Appliance available;
 - (c) have the proof of purchase (e.g. an invoice) available;
 - (d) telephone the numbers shown below.
14. You accept that if you make a warranty claim, Electrolux and its ASC may exchange information in relation to you to enable Electrolux to meet its obligations under this warranty.

Important Notice

Before calling for service, please ensure that the steps listed in clause 13 above have been followed.

<p>FOR SERVICE or to find the address of your nearest state service centre in Australia PLEASE CALL 13 13 49 <small>For the cost of a local call (Australia only)</small></p>	<p>SERVICE AUSTRALIA ELECTROLUX HOME PRODUCTS electrolux.com.au</p>	<p>FOR SPARE PARTS or to find the address of your nearest state spare parts centre in Australia PLEASE CALL 13 13 50 <small>For the cost of a local call (Australia only)</small></p>
<p>FOR SERVICE or to find the address of your nearest authorised service centre in New Zealand FREE CALL 0800 10 66 10 <small>(New Zealand only)</small></p>	<p>SERVICE NEW ZEALAND ELECTROLUX (NZ) Limited electrolux.co.nz</p>	<p>FOR SPARE PARTS or to find the address of your nearest state spare parts centre in New Zealand FREE CALL 0800 10 66 20 <small>(New Zealand only)</small></p>

For more information on all Westinghouse appliances, or for dimension and installation information, call into your retailer, phone or email our customer care team or visit our website:

AUSTRALIA

phone: 1300 363 640

fax: 1800 350 067

email: customercare@electrolux.com.au

web: westinghouse.com.au

NEW ZEALAND

phone: 0800 436 245

fax: 0800 225 088

email: customercare@electrolux.co.nz

web: westinghouse.co.nz

TOP SERVICE

Top Service encompasses the after sales service provided by The Electrolux Group to consumers including delivery, home service and spare parts.

 and WESTINGHOUSE are trademarks of Westinghouse Electric Corporation. Used under license. All Rights Reserved.

P/No A02346001 Issue C

© 2016 Electrolux Home Products Pty Ltd.
ABN 51 004 762 341
WMAN_CHOB_Oct16